

This form is the approved form that must be used in accordance with section 10 of the *Building Act 1975* and sections 73 and 77 of the *Building Regulation 2021* (Design-specification certificate) stating that an aspect of building work or specification will, if installed or carried out as stated in this form, comply with the building assessment provisions.

Additional explanatory information is included in the Appendix at the end of this form.

<p><b>1. Property description</b></p> <p>This section need only be completed if details of street address and property description are applicable.</p> <p>E.g. in the case of (standard/generic) pool design/shell manufacture and/or patio and carport systems this section may not be applicable.</p> <p>Where applicable, the description must identify all land the subject of the application.</p> <p>The lot and plan details (e.g. SP/RP) are shown on title documents or a rates notice.</p> <p>If the plan is not registered by title, provide previous lot and plan details.</p>	<p>Street address <i>(include number, street, suburb/locality and postcode)</i></p> <p>.....</p> <p>..... State <u>QLD</u> Postcode .....</p> <p>Lot and plan details <i>(attach list if necessary)</i></p> <p>.....</p> <p>Local government area the land is situated in</p> <p>.....</p>
<p><b>2. Description of aspect/s certified</b></p> <p>Clearly describe the extent of work covered by this certificate, e.g. all structural aspects of the steel roof beams.</p>	<p>Design of the Level Master Rod Bracing Set as detailed on the attached drawings</p>
<p><b>3. Basis of certification</b></p> <p>Detail the basis for giving the certificate and the extent to which tests, specifications, rules, standards, codes of practice and other publications were relied upon.</p>	<p>NCC 2022 Building Code of Australia  AS 1170.0 2002 Structural design action – general principals  AS 1170.1 2002 Permanent, imposed, and other actions  AS 1170.2 2021 Structural design actions – Wind Actions  AS 4100 2020 Steel structures</p>

<p><b>4. Reference documentation</b></p> <p>Clearly identify any relevant documentation, e.g. numbered structural engineering plans.</p>	<p>PEER Consulting Engineers Pty Ltd – Drawing PCE2247.2 – Rev 0, MAY 2023 Design Certification - LEVELMASTER - Rod Bracing set</p>
--	---

<p><b>5. Building certifier reference number and building development application number</b></p>	<p>Building certifier reference number</p> <p>.....</p> <p>Building development application number <i>(if available)</i></p> <p>.....</p>
--	---

<p><b>6. Appointed competent person details</b></p> <p>Under Part 6 of the Building Regulation 2021 a person must be assessed as a competent for the type of work (design-specification) by the relevant building certifier.</p>	<p>Name <i>(in full)</i> <b>Mengting Zhao</b></p> <p>.....</p> <p>Company name <i>(if applicable)</i> <span style="float: right;">Contact person</span> <b>PEER Consulting Engineers</b></p> <p>.....</p> <p>Business phone number <span style="float: right;">Mobile number</span> <b>07 3209 4702</b></p> <p>.....</p> <p>Email address <b>info@peerce.com.au</b></p> <p>.....</p> <p>Postal address <b>4B/2404 Logan Road</b></p> <p>.....</p> <p><b>Eight Mile Plains</b> State <b>QLD</b> Postcode <b>4113</b></p> <p>.....</p> <p>Licence class or registration type <i>(if applicable)</i> <b>RPEQ</b></p> <p>.....</p> <p>Licence or registration number <i>(if applicable)</i> <b>24534</b></p> <p>.....</p>
--	---

<p><b>7. Signature of appointed competent person</b></p> <p>This certificate must be signed by the individual assessed and appointed by the building certifier as competent to give design-specification help.</p>	<p>Signature <span style="float: right;">Date</span></p> <p style="text-align: center;">  </p> <p>..... <span style="float: right;"><b>01/05/2023</b></span></p> <p style="text-align: right;">*This certificate expires on 30/04/2024</p>
--	--

**LOCAL GOVERNMENT USE ONLY**

<b>Date received</b>		<b>Reference number/s</b>	
----------------------	--	---------------------------	--

## Appendix – explanatory information

**IMPORTANT NOTE:** it is an offence for a competent person to give a building certifier a document, including this form, that the person knows or reasonably suspects, is false or misleading.

**Who can complete this certificate?** (section 10 of the *Building Act 1975* (Building Act) and sections 73 and 77 of Building Regulation 2021 (BR 2021))

A building certifier can accept from a competent person (design-specification) a certificate stating that the competent person has assessed the building design or specification for the aspect of building work, and it will, if installed or carried out under the certificate, comply with the building assessment provisions, including any relevant standards and codes.

Schedule 10 of the BR 2021 defines *building design or specification* as any material, system, method of building or other thing related to the design of or specifications for building work.

When completing the certificate, a competent person is required under section 77 of the BR 2021 to include the basis for giving the certificate and state the extent to which the competent person has relied on tests, specifications, rules, standards, codes of practice or other publications.

**What is the purpose of this form?** (section 10 of the Building Act and sections 73 and 77 of the BR 2021)

The information in this form informs the building certifier's decision making when they are assessing a building development application, issuing the building development approval for the building work the subject of the certificate (form) and when amending the building development approval due to the receipt of updated aspect information such as glazing or truss specifications or revised excavation drawings.

**Can a manufacturer or supplier give this Form 15?**

A building certifier can accept this form from a manufacturer or supplier who the certifier has decided is a competent person (design-specification).

A manufacturer or supplier of building materials can give this form if they have undertaken the design component for the product. For example a window manufacturer who designs, constructs and supplies the windows to industry could give this form.

**Competent person** (section 10 of the Building Act 1975 and Part 6 of the BR 2021)

A building certifier must assess and decide to appoint an individual as a competent person before they can accept design-specification help.

When deciding whether a person can be a competent person, the building certifier must assess the person having regard to their experience, qualifications and skills and ensure the person holds a licence or registration if required.

The building certifier is required to keep detailed records about what was considered when appointing a competent person.

For further information about assessment of someone as a competent person refer to the **Guideline for the assessment of competent persons**.

**What is required if a manufacturer or supplier did not do the design work for the product?**

A manufacturer or supplier who is not part of the design process may give the construction contractor, builder, competent person or the building certifier evidence of suitability such as a product technical statement under Part A5 of the Building Code of Australia (BCA), for an aspect or material stating that it is compliant with the relevant reference documents in the BCA i.e. the applicable Australian Standard/s.

**What if there is not enough space for all the supporting material/documents?**

Items 2, 3 and 4 requires the competent person to clearly identify the extent of the assessment that was undertaken for aspect/s of work identified in this form.

For instance, there is provision for material such as specifications, standards, codes or other relevant publications to be referenced in the form. However, if the space in the form is not sufficient to accommodate all of this material, you can create and refer to additional material in an addendum or attachment to the form.

The form is also available in a Microsoft Word version, that you can download and edit to include additional material in the relevant parts of the form. Note that editing the form in the Microsoft Word version may cause the relevant boxes to expand and increase the length of the document. This is acceptable and does not change the approved form, provided the section text (description on the left-hand side of the page) is not altered.

**Appointed competent person (design or specification)** – (sections 34 and 36 of the BR 2021)

A building certifier must assess and decide to appoint an individual as a competent person before they can, as a competent person, give design-specification help. The building certifier is required to keep detailed records about what was considered when appointing a competent person.

A building certifier must be satisfied that an individual is competent to give the type of help having regard to the individual's experience, qualifications and skills and if required by law to hold a licence or registration, that the individual is appropriately registered or licensed.

An individual is appointed as competent to give design-specification help on or from a particular day.

For further information about assessment of someone as a competent person refer to the **Guideline for the assessment of competent persons**.

**PRIVACY NOTICE**

The Department of Energy and Public Works is collecting personal information as required under the *Building Act 1975*. This information may be stored by the Department, and will be used for administration, compliance, statistical research and evaluation of building laws. Your personal information will be disclosed to other government agencies, local government authorities and third parties for purposes relating to administering and monitoring compliance with the *Building Act 1975*. Personal information will otherwise only be disclosed to third parties with your consent or unless authorised or required by law.

**BRACING NOTES**

- 1 THREAD HEIGHT MEASURED FROM TOP OF NUT TO UNDERSIDE OF FIXING TOP PLATE.
- 2 CAST IN COLUMNS MAY HAVE CAPACITIES THAT EXCEED THOSE IN TABLE-1 BELOW. THIS IS TO BE CONFIRMED AND DESIGNED BY THE PROJECT ENGINEER.
- 3 BRACING ANGLES IN EXCESS OF 45° MAY REQUIRE ADDITIONAL HORIZONTAL BRACING. THIS IS TO BE DESIGNED BY THE PROJECT ENGINEER.
- 4 BRACING MAY BE FIXED TO BEARERS. THIS IS TO BE DESIGNED BY THE PROJECT ENGINEER TO SUIT THE BEARER BEING USED.

**NOTE 1**  
 THE M16 BRACING ROD (WITH TURNBUCKLE)  
 ASSEMBLY TENSION CAPACITY = 27kN

ALL SCREWS TO BE CLASS 4  
 12g (24TPI) FROM ICCONS PTY LTD.

ALL STEEL TO BE G250 (U.N.O).

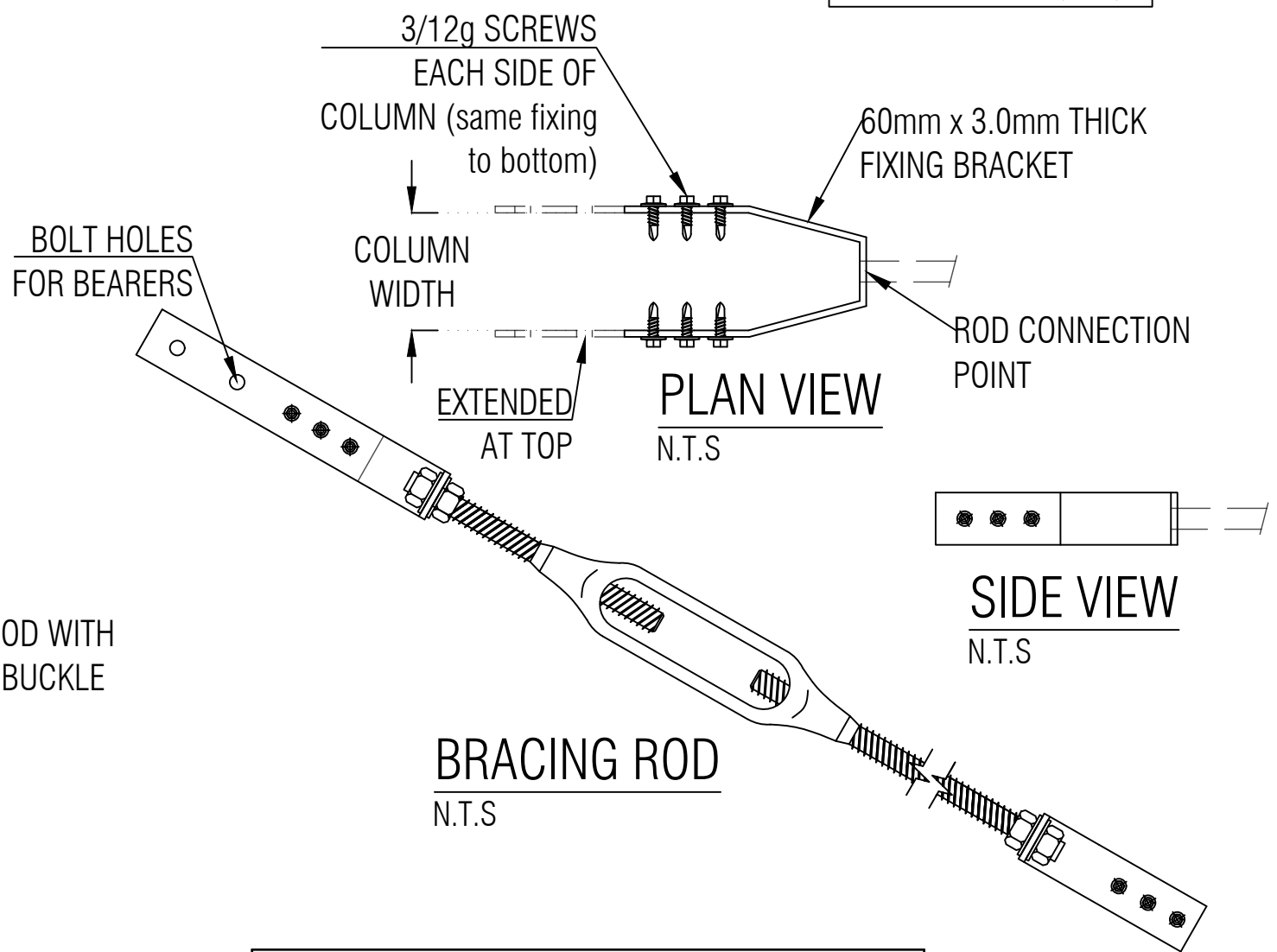
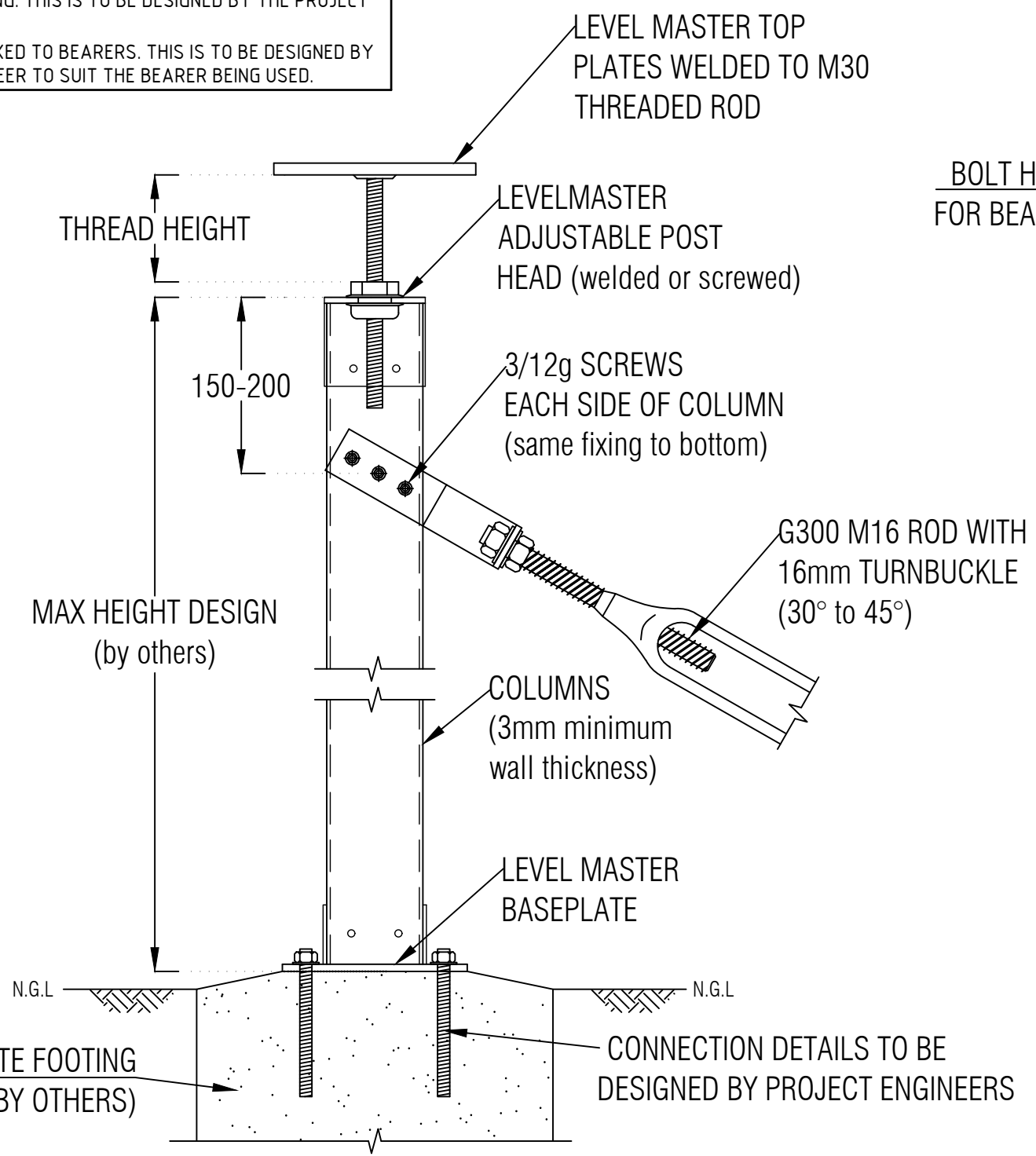

**NOTE 2**  
 IF THE M16 BRACING ASSEMBLY TO BE USED WITH LEVELMASTER ADJUSTABLE POST HEAD SYSTEMS, THE TOTAL RACKING CAPACITIES COULD BE DOMINATED BY THE POST HEAD COMPONENTS. REFER TO THE TABLE BELOW:

BRACING SET RACKING CAPACITIES	
THREAD HEIGHT (mm)	TOTAL RACKING CAPACITY (kN)
25	18.0
50	9.0
75	6.0
100	4.5

DO NOT SCALE FROM DRAWING  
 ALL SCALES ARE AS SHOWN (A3)

REV.	DESCRIPTION	DATE	INIT.
A	PRELIMINARY ISSUE	MAY2023	J.L.
0	FOR CERTIFICATION	MAY2023	J.L.

**PEER Consulting Engineers**  
 Professional Economical Efficient Reputable

**CONTACT DETAILS**  
 EMAIL info@peerce.com.au  
 WEB www.peerce.com.au  
 PHONE 07 3841 2046  
 POST 4B/2404 LOGAN RD,  
 EIGHT MILE PLAINS  
 QLD 4113

**CLIENT**  
 LEVEL MASTER

**PROJECT**  
 TYPICAL ROD BRACING SET

**TITLE**  
 ROD BRACING CONNECTIONS

DRAWN	DESIGNED	DATE
J.L.	-	MAY 2023
CHECKED	APPROVED	
N.Z.		
DRAWING No.	REV.	
PCE2247-2 - S01	0	