

## Generic Structural Design Certificate LEVELMASTER – Rod Bracing Set

01/05/2023

To whom it may concern,

We, **PEER Consulting Engineers** certify that we have designed and reviewed the LevelMaster Rod Bracing Set as detailed on the listed drawing below, and they have been designed in accordance with widely accepted engineering principles and the referenced codes of practice. This certificate is limited to the structural design only and no responsibility is taken for any loss, damage or failure resulting from the method of construction or wind exceeding the design wind rating nominated.

### Referenced Codes of Practice and Manuals:

NCC 2022 Building Code of Australia  
AS 1170.0 2002 Structural design action – General principals  
AS 1170.1 2002 Permanent, Imposed and Other Actions  
AS 1170.2 2021 Structural Design Actions – Wind Actions  
AS 4100 2020 Steel Structures

### Referenced Design Documents:

PEER Consulting Engineers Pty Ltd – Drawing Set PCE2247.2 – Rev 0, MAY 2023

PEER Consulting Engineers maintains indemnity insurance concordant with the scope of the undertaken works to the satisfaction of its Client; however, our involvement in this shall in no way be construed of relieving other parties of their legal obligations.

If you require any further information, please do not hesitate to contact us at any time.

Sincerely,



### **Mengting (Nike) Zhao**

B.Eng (1<sup>ST</sup> Class Hons.) MIEAust, RPEQ, RPEng  
Director/  
Principal Civil and Structural Engineer

**\*This certificate expires on 30/04/2024.**

**BRACING NOTES**

- 1 THREAD HEIGHT MEASURED FROM TOP OF NUT TO UNDERSIDE OF FIXING TOP PLATE.
- 2 CAST IN COLUMNS MAY HAVE CAPACITIES THAT EXCEED THOSE IN TABLE-1 BELOW. THIS IS TO BE CONFIRMED AND DESIGNED BY THE PROJECT ENGINEER.
- 3 BRACING ANGLES IN EXCESS OF 45° MAY REQUIRE ADDITIONAL HORIZONTAL BRACING. THIS IS TO BE DESIGNED BY THE PROJECT ENGINEER.
- 4 BRACING MAY BE FIXED TO BEARERS. THIS IS TO BE DESIGNED BY THE PROJECT ENGINEER TO SUIT THE BEARER BEING USED.

**NOTE 1**  
 THE M16 BRACING ROD (WITH TURNBUCKLE)  
 ASSEMBLY TENSION CAPACITY = 27kN

ALL SCREWS TO BE CLASS 4  
 12g (24TPI) FROM ICCONS PTY LTD.

ALL STEEL TO BE G250 (U.N.O).

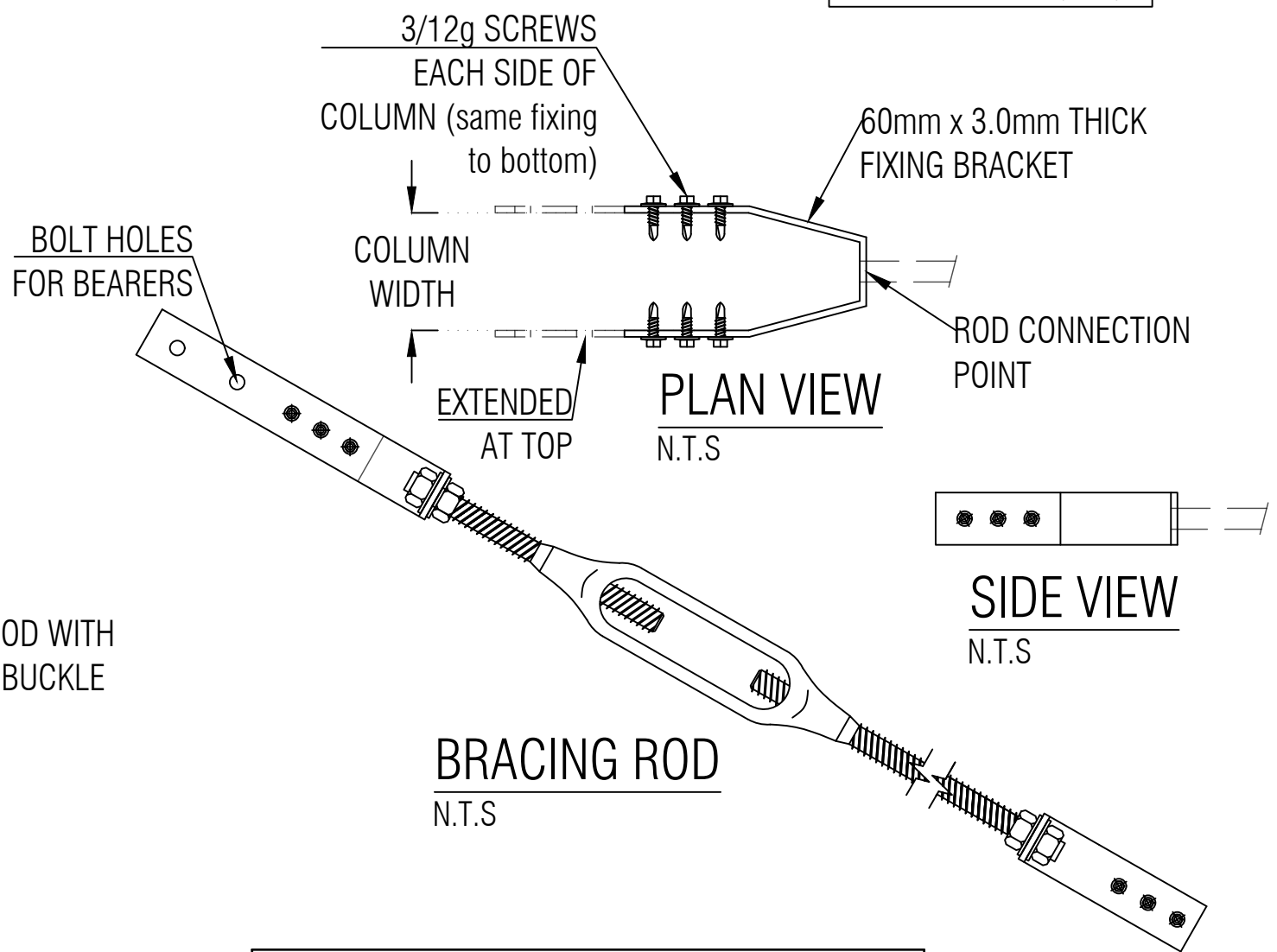
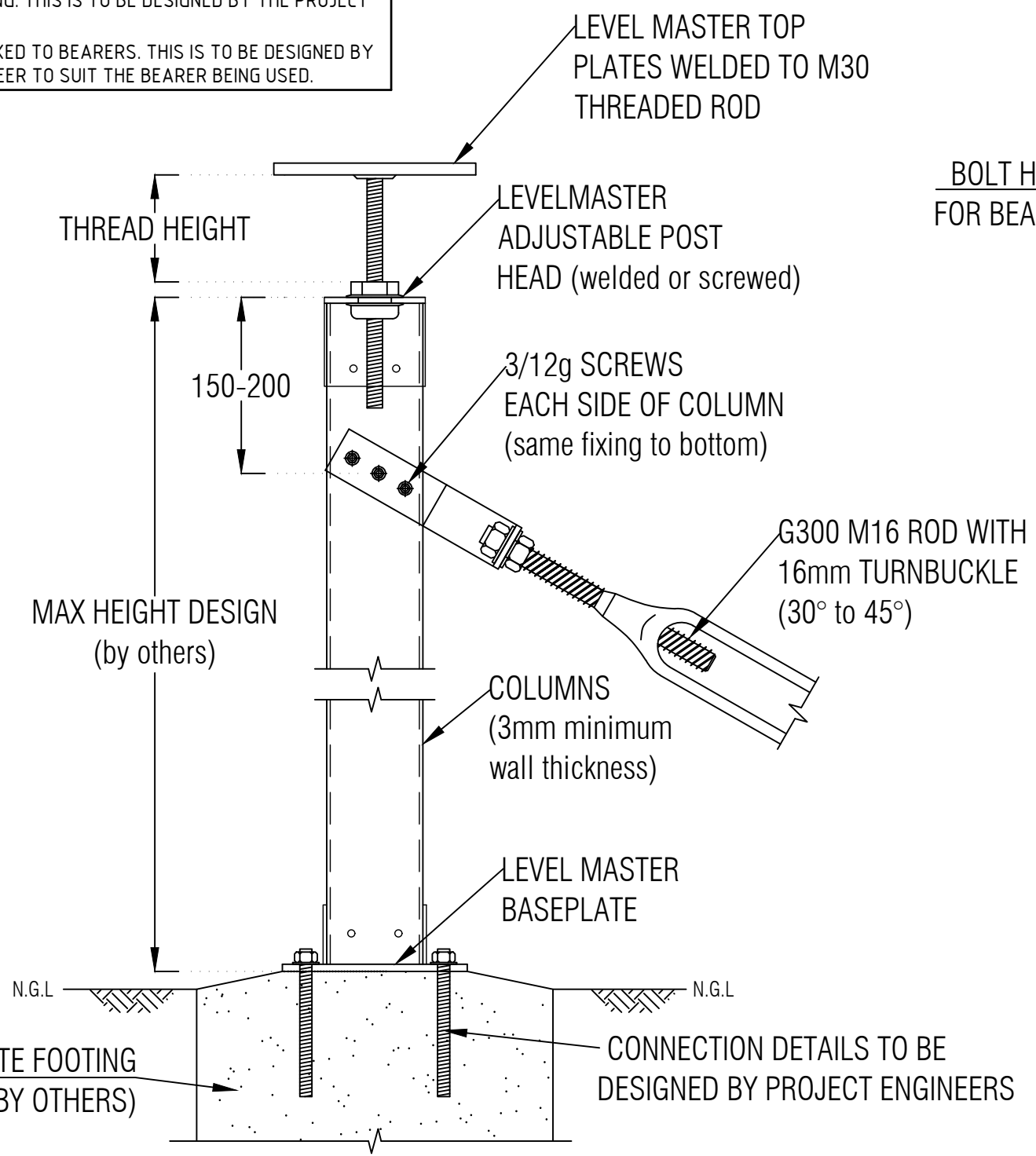

**NOTE 2**  
 IF THE M16 BRACING ASSEMBLY TO BE USED WITH LEVELMASTER ADJUSTABLE POST HEAD SYSTEMS, THE TOTAL RACKING CAPACITIES COULD BE DOMINATED BY THE POST HEAD COMPONENTS. REFER TO THE TABLE BELOW:

BRACING SET RACKING CAPACITIES	
THREAD HEIGHT (mm)	TOTAL RACKING CAPACITY (kN)
25	18.0
50	9.0
75	6.0
100	4.5

DO NOT SCALE FROM DRAWING  
 ALL SCALES ARE AS SHOWN (A3)

REV.	DESCRIPTION	DATE	INIT.
A	PRELIMINARY ISSUE	MAY2023	J.L.
0	FOR CERTIFICATION	MAY2023	J.L.

**PEER Consulting Engineers**  
 Professional Economical Efficient Reputable

**CONTACT DETAILS**  
 EMAIL info@peerce.com.au  
 WEB www.peerce.com.au  
 PHONE 07 3841 2046  
 POST 4B/2404 LOGAN RD,  
 EIGHT MILE PLAINS  
 QLD 4113

**CLIENT**  
 LEVEL MASTER

**PROJECT**  
 TYPICAL ROD BRACING SET

**TITLE**  
 ROD BRACING CONNECTIONS

DRAWN	DESIGNED	DATE
J.L.	-	MAY 2023
CHECKED	APPROVED	
N.Z.		
DRAWING No.	REV.	
PCE2247-2 - S01	0	